

[Visit www.boighill.com](http://www.boighill.com) to request a quote.



USER INSTRUCTIONS

Worcester Actuation Systems

Series 75 Electric
Valve Actuator

FCD WCAIM2013-01 – 08/04 (Replaces IOM-12156)

Installation
Operation
Maintenance



Experience In Motion

[Visit www.boighill.com](http://www.boighill.com) to request a quote.



Contents

Description	3
Installation	3
Electrical Installation and Adjustment	4
Options and Adjustments (Factory Installed)	6
Center-Off (180° Rotation)	6
Feedback Potentiometers (Single, Dual)	8
I-75 Interface	10
Extra Limit Switches (M1 or M2)	11
Mechanical Brake (10-2375 Actuators)	11
Cycle Length Control (CLC Module)	11
Heater and Thermostat	12
Drain/Breather (V53) Option (10-2375 Actuators)	12
4-75 Position Indicator	12
Manual Operation	13
Maintenance and Troubleshooting	13
Electrical Requirements	14
Electrical Schematics (Series 75)	15
Electrical Schematics and Wiring Diagrams for Options (Series 75)	16
Parts List	18



Description

Worcester Actuation Systems/McCANNA Series 75 actuators are reversible electric quarter-turn valve actuators. Standard units can provide up to 3000 in-lb of torque and have capacitor-start, capacitor-run motors and permanently lubricated gear trains. These actuators are equipped with integral thermal overload protection (AC motors only) with automatic reset and internal adjustable limit switches. In the event of electrical power failure, W, X and Z models feature manual override capabilities.

⚠ WARNING: Series 75 actuators are electromechanical devices subject to normal wear and tear. Actuator life is dependent upon application and environmental conditions. If applied in hazardous services, such as but not limited to, media temperature extremes, toxins, flammables, or other services where improper or incomplete operation could produce a safety hazard, it is incumbent upon the system designer and the user to provide proper warning devices such as temperature sensors, oxygen sensors and flow sensors. At elevated temperatures the duty cycle has to be derated, consult factory. Flowserve also recommends that the optional auxiliary limit switches be used for monitoring and/or electrical interlock. Heater with thermostat as well as drain/breather fitting (V53 option) are recommended for humid environments when moisture may condense inside the housing. Please note that weatherproof enclosures will “breathe” over time and condensation within the housing will result.

⚠ CAUTION: For actuators with dual DC motor module, failure of one motor may mechanically damage the gear train.

⚠ CAUTION: Flowserve recommends that all products, which must be stored prior to installation, be stored indoors, in an environment suitable for human occupancy. Do not store product in areas where exposure to relative humidity above 85%, acid or alkali fumes, radiation above normal background, ultraviolet light, or temperatures above 120°F or below 40°F may occur. Do not store within 50 feet of any source of ozone.

⚠ CAUTION: For wiring of actuator, including options, please refer to wiring diagram(s) located inside of actuator cover. Wiring diagrams are also included in this manual for reference.

Installation

A. Attach mounting bracket to actuator using four (4) cap screws and lockwashers, provided in mounting kit, and tighten securely. For small size top mount style valves, attach bracket such that bracket nameplate will be to side of valve.

For mounting to 818/828 Series valves, insert ISO locating ring into groove on bottom of actuator before attaching to bracket. Note: Ring can be permanently held in groove by applying Loctite to ring before inserting in groove.

B. Attach bracket/actuator assembly to valve as follows:

NOTE: If cross-line mounting of actuator is desired, note the following:

Mount the actuator with conduit hole perpendicular to the flow axis (centerline) of the valve and reverse the open/close decals.

For diverter and three-way valves with V1 porting, and CPT valves, also see Electrical Installation and Adjustment Section, Paragraph D, for cam and limit switch adjustments to facilitate cross-line mounting operation.

⚠ CAUTION: Ball valves can trap pressurized media in the cavity. If it is necessary to remove any valve body bolts, stem nuts, or remove valve from the line, and if the valve is or has been in operation, make sure there is NO pressure to or in the valve and operate the valve one full cycle.

1. Valve Models Top Mount 44 (1/4"–2"), 45 (2 1/2"–6"), 51/52 (1/2"–10"), 151/301 (3"–6"), Top Mount 59 (1/4"–4"), WK70/WK74 and H71 (1/2"–2"), 818/828 (2"–8"), 82/83 (1/2"–10"), and 94 (1/2"–6"):

NOTE: For above listed valves, it is not necessary to remove any valve body bolts or remove valve from line in order to mount actuator.

a. Close valve (for valves 1/4"–2", the valve is closed when flats on valve stem are perpendicular to the line of flow; for valves 3" and larger, where the valve stem is square, the indicator line on top of stem will be perpendicular to the line of flow or check ball position for closure).

b. If any valve information is marked on stop plate or handle, it will be necessary to transfer this information to the bracket nameplate.

For 1/4"–2" 44 and 1/2"–2" WK70/WK74, 1/4"–1 1/2" 59 and 1/2"–1 1/2" H71 Series top mount style valves and 1/2"–2" 51/52, 1/2"–1 1/2" 82/83 Series valves with high cycle stem packing as standard, remove handle nut, lockwasher, handle, separate stop plate (if any), retaining nut and stop

pin(s). Add the two additional Belleville washers with their larger diameter sides touching each other. Add the self-locking nut to the stem and tighten while holding the stem flats with wrench. Tighten until Belleville washers are flat, the nut will “bottom”, and then back nut off 1/8 turn. The two additional Belleville washers and the self-locking nut are included in the mounting kit.

▲ CAUTION: The self-locking stem nut is difficult to tighten, and must fully flatten Belleville washers before backing off.

For 2" 59, H71, 82/83, and 2 1/2" 45, 82/83 Series valves and valves 3" and larger with square stem, remove handle assembly (if any), retaining nut, stop and stop screws. Replace with valve stem spacer or, if valve has graphite stem packing, with two Belleville washers (except 8", 10" 82/83 and 10" 51/52) and replace retaining nut. NOTE: Belleville washers are installed with larger diameters touching each other. Using a wrench to prevent stem from turning, tighten retaining nut until stem packing is fully compressed or Bellevilles, if used, are fully flattened, then back off nut 1/8 turn. Excessive tightening causes higher torque and shorter seal life.

NOTE: Large valves with V51 high cycle stem packing option installed, identified by two Belleville washers installed and handle assembly, stop and stop screws removed, and 818/828 Series valves do not require stem area disassembly.

For 1/2"-2" 94 valves, remove handle (if any). For 3"-6" 94 and 2"-8" E818/E828 valves, remove handle assembly, stop, and spacer (if any). Do NOT remove gland plate or gland bolts.

For 2"-8" 818/828 valves, remove handle assembly, locking plates and hardware, and stop screw (if any). Do not remove stop plate (2"-6" sizes) or spacer (8" size).

- c. Center coupling on valve stem.
- d. Lower mounting bracket/actuator assembly over coupling and onto valve, making sure that male actuator shaft engages slot in coupling.
- e. Secure bracket to valve using cap screws and lockwashers, or bolts and nuts provided in mounting kit. Tighten securely. For small size top mount style valves, bracket nameplate will be to side of valve.
- f. Install set screws (if any) in the coupling and tighten securely.

C. Series 75 actuator in modulating control service and interface with PC and/or computer.

1. Series 75 actuators can be used for modulating control service operated directly by programmable controller or computer under specific conditions as follows:
 - a. To achieve stable control, an actuator with a longer cycle time is recommended.
 - b. To eliminate overheating from frequent startups, 75% or 100% duty cycle actuators are required.
 - c. To eliminate problems with interfacing, and to protect the output circuitry of the controller, use Worcester I-75 interface board.
2. Alternately a controller coupled with a Series 75 actuator must have:
 - a. Two outputs (one to open, one to close) per actuator being controlled.
 - b. Nine amp minimum output rating.
 - c. Buffered Output – Resistor and capacitor wired in series across each triac.

If a controller output does not meet these requirements, two relays (one to open, one to close) may be installed between controller and each actuator. Failure to observe these precautions will result in controller output damage.

Electrical Installation and Adjustment

▲ CAUTION: It is recommended that the actuator motor not be driven directly from the PLC output. The inrush current/back EMF can destroy the PLC output card triacs if they are not of sufficient rating. As a minimum these should be rated 800 volt, 12 amp triacs. In addition to these ratings, snubber circuits should be utilized to help protect the triacs. This applies to 120 VAC motors only. 240 VAC motors should never be driven directly from a PLC output card.

A. To gain access to terminal strip, it is necessary to remove the actuator cover.

10-2275 (General Purpose) Loosen cover screws and lift cover from unit.

10-2375 W, X and Z Remove declutch knob screw and lift knob from shaft. Remove the two cover screws from cover (the other



six screws are in an envelope and inside the cover) and lift cover from unit.

25-3075 Z Remove indicator knob capscrew with Allen wrench and lift knob from shaft. Remove the cover screws and lift cover from unit.

- B. Make conduit connection to NPT fitting on actuator base. Connect power supply to actuator terminal strip as shown on electrical schematic diagram(s) located inside actuator cover and also in this manual.

The actuator should be electrically grounded in accordance with standard procedures.

For 10-2375 W, X and Z actuators, connect a CSA certified No. 18 AWG green-colored grounding wire to the green-colored grounding screw on actuator base.

For 10-2275 GP actuators, connect a CSA certified No. 18 AWG green-colored grounding wire to terminal marked "G" on actuator terminal strip.

For 25 and 3075 Z actuators, connect a CSA certified No. 18 AWG green-colored grounding wire with a ring-type crimp wire connector and a washer to the green-colored grounding screw (near terminal strip) marked with a letter "G" on motor support plate.

See table below for minimum fuse rating when overcurrent protection is used in motor power circuit.

▲ CAUTION: In cases where the conduit connected to the actuator may be partially or completely run underground, or through which moisture may contact energized live parts, or where the actuator and/or conduit is exposed to temperature differences, the conduit should be sealed within 18" of the actuator in accordance with the National Electrical Code.

Minimum Fuse Rating for Overcurrent Protection

Actuator Size	Voltage	Fuse Rating (A)
10-23	120 VAC	5A
25/30	120 VAC	10A
10-23	240 VAC	3A
25/30	240 VAC	5A
10-23	12 VDC	10A
10-23	24 VDC	5A

NOTE: The table shows the minimum rating to prevent inrush current from blowing the fuse.

- C. When electrical installation is complete, it is advisable to check the indexing of the actuator before replacing the cover.

10-3075 (All): Move actuator to "Open" position (apply power to Terminals 1 and 3). If it does not fully open, or turns past open position, unfasten cam of switch SW2 by loosening set screw (SW2 is to the left of the shaft looking from terminal strip). Move actuator to correct position. Adjust cam so that it just throws micro switch in this position. Tighten set screw and recheck indexing. Repeat this procedure for "Closed" position (apply power to Terminals 1 and 4). **WARNING:** Do not bend switch arms when adjusting cams for actuator travel limits. Doing so will damage the cams.

NOTE: If one or more of the options listed in Options and Adjustments Section have been installed, follow specific instructions for those options as necessary before replacing cover.

- D. If actuator has been cross-line mounted and valve is a diverter or three-way with V-1 porting or CPT valve, proceed as follows:

Reset both cams to operate in next quadrant, (when looking down at cover, the "next" quadrant is 90° clockwise from standard quadrant, one quadrant closer to conduit connection). Switch #1 is the "to close" switch, and is connected to Terminal #4. Switch #2 is "to open", goes to Terminal #3. CPT valves must operate "clockwise to close" viewed from top. Relocate decals to new quadrant. "Open" is 90° from conduit side, "close" is adjacent to conduit side. If mounted on a V-1 diverter, "open" shall expose ball port at one pipe end, "closed" shall expose ball port at the opposite pipe end.

- E. Replace actuator cover.

NOTE: For W and Z models, make sure flange gasket/seal is properly installed. Tighten all cap screws securely.

For X and Z Models Only:

After placing the cover on the actuator, tighten the cover bolts in a crisscross fashion to a torque of 70-80 in-lbs.

A feeler gage, being 1/8" to 1/2" wide and 0.0015" thick, shall be used to check the clearance between the base and cover flange.

This feeler gage shall not penetrate the base/cover flange gap any more than 1/8".

10-2375 W, X and Z: Replace declutching knob, taking care that knob set screw engages milled flat on clutch shaft and indicates proper position on labeled cover.

25-3075 Z: Replace indicator knob in its proper position to give correct indication. Tighten indicator's cap screw securely.

Options and Adjustments (Factory Installed)

NOTE: For wiring of the following options, please refer to the appropriate option wiring diagram(s) located inside actuator cover or included with option kit. Wiring diagrams for most options are also included in this manual for reference.

All wiring to terminal strip should be inserted only to mid-point of terminal strip.

For some options with AC actuators, multiple wires are going to terminal 1. A short white wire is provided and connected to terminal 1, then spliced to the other white wires (common) using a closed end splice.

A. Center-Off (180° Rotation)

1. Readjustment of "Center-Off" Cams (if necessary):
 - a. With the cover removed and the actuator placed with the terminal strip facing the operator, switches 1 and 3 are to the right and switches 2 and 4 are to the left of the main shaft.
 - b. There are four cams and two spacers on the shaft. Per the drawing on the following page, these cams are numbered 1 through 4, from bottom to top. (See proper drawing for approximate location and correct orientation of the center-off cams.)
 - c. Using the manual override (see page 12) as necessary, set the actuator shaft to a "center-off" location.

Set cam #3 such that hook of switch 3 lever arm has just dropped off the cam. Tighten cam screw without moving cam.

▲ CAUTION: Do not bend the limit switch lever arm.

Set cam #4 such that hook of switch 4 lever arm will match the arch of cam #4. Tighten cam screw without moving cam.

▲ CAUTION: Do not bend the limit switch lever arm.

Release manual override.

- d. Power the actuator to the full clockwise (CW) limit, to the 0° reference position. Check position of ball and valve stem to verify that valve is in the true 0° position, as required by the application.
- e. Repeat the above step for the 180° or full CCW position. Verify that the driven device is in the required position.
- f. Apply power to terminals 1 and 7 for AC (+ to 7 and - to 8 for DC) to verify proper operation of center-off switches. With the actuator shaft positioned at the 180° position, power applied to terminals 1 and 7 for AC (+ to 7 and - to 8 for DC) moves the actuator shaft clockwise (CW) to the center-off position.

With the actuator shaft at the full clockwise position, 0 degrees, apply power to terminals 1 and 7 for AC (+ to 7 and - to 8 for DC). The actuator shaft should move counter-clockwise CCW to the center-off position.

180° Center-Off Actuator Series 75W, X, And Z Shown

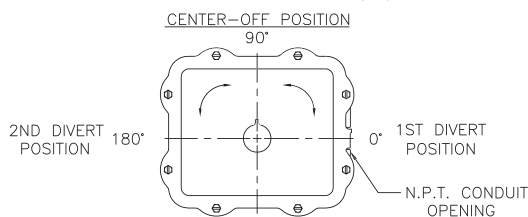

Standard 90° Actuator Series 75W, X, and Z Shown

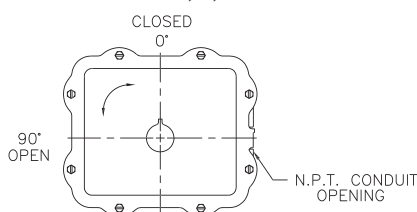

Typical View Showing Location of Center-Off Cams and Limits Switches Set Up at the Center-Off Position

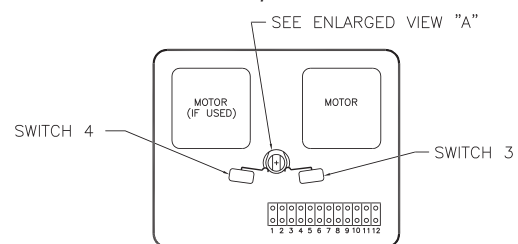

View "A"

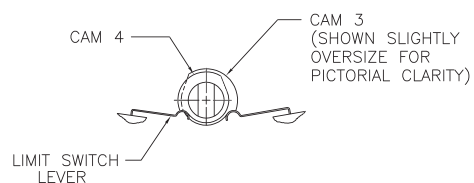

SPECIAL NOTE: If during any of these checks, the actuator shaft stops other than at the required positions, a readjustment of the center-off cams is needed. At no time shall both center-off switches be activated by their cams at the same time. The N.O. contacts on both center-off switches are typically closed. The center-off switch levers must be tripped by their center-off cams at different times.

Therefore, the center-off cams should be set as close to the 90 degree position as possible, yet the cam/switch actuation for each switch is never at the identical position.

If the center-off switches are set to actuate at a close angular differential, the actuator shaft may oscillate, or not operate. Loosen one cam and move this cam to increase the actuation differential between each of the center-off switches.

If the center-off switches are set to actuate at a wide angular differential, the actuator will not stop at a true center-off position. Adjust one or both cams to decrease the angular differential between each of these switches.

- g. As a final check, alternately apply power to terminals 1 and 4, 1 and 3, and 1 and 7 for AC, (+ to the 1 and - to the 4; - to 1 and + to 3; - to 8 and + to 7 for DC).

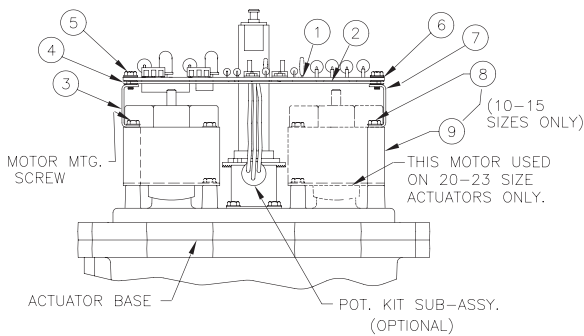

10-23 Size 75 Actuators

Item	Description
1	Circuit Board Sub-Assembly
2	Insulating Board
3	Bracket-Right (Long)
4	Grommet-Rubber
5	Mounting Screws (Cir. Board)
6	Washer-Nylon
7	Bracket-Left (Short)
8	Mounting Screws (Bracket)
9	Spacer (Bracket)

No oscillation or hunting of the actuator output shaft should occur.

If the above problems are noted, simply readjust the center-off cams as noted in Step f.

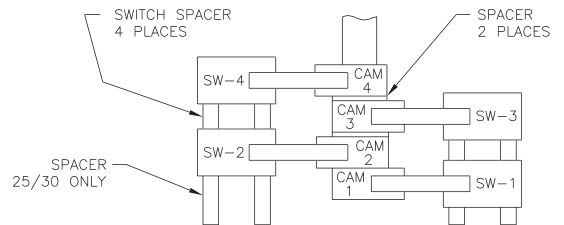

Switch configuration is as above (when viewed from the terminal strip side of the actuator).

Actuator shown at 0° position (fully CW).

120 VAC Shown

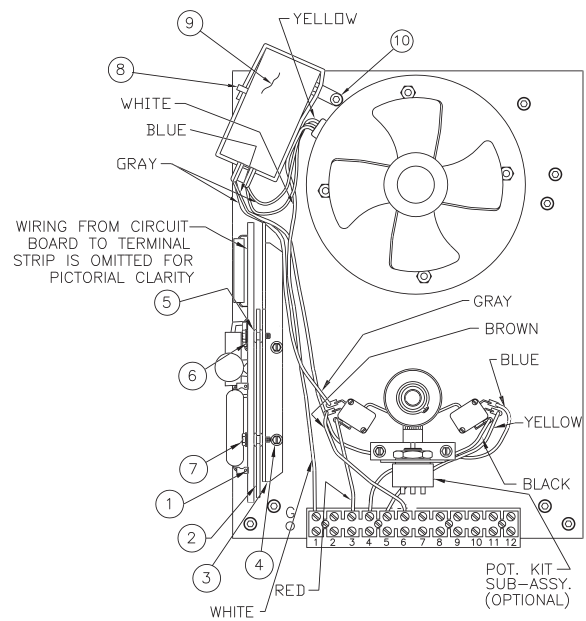

25-30 Size 75 Actuators

Item	Description
1	Circuit Board Sub-Assembly
2	Insulating Board
3	Circuit Board Bracket
4	Mounting Screw (Bracket)
5	Grommet-rubber
6	Washer-Nylon
7	Mounting Screw (Cir. Board)
8	Capacitor (Round Or Rectangular)
9	Capacitor Tie (See Note)
10	Capacitor Bracket And Screw (See Note)

Note: Not Used For Round Type Capacitor With Threaded Lug.



Cam settings are as follows:

Switch 1 opens at 0°. Controls first divert position.

Switch 2 opens at 180°. Controls second divert position.

Switch 3 opens at 89°. Controls center-off position from first divert position.

Switch 4 opens at 91°. Controls center-off position from second divert position.

NOTE: Switches 1 and 2 and Cams 1 and 2 are standard. Switches 3 and 4 and Cams 3 and 4 are center-off type.

Use cam spacer as needed to line up cam and switch.

B. Feedback Potentiometers (Single, Dual)

The potentiometer, as part of the Series 75 Actuator, is used to obtain feedback representing the actuator's position. It requires a power supply, which may be furnished by the end user and/or by optional devices such as a 4-75 (4-20 mA) Position Indicator or AF17 Positioner.

A Dual Potentiometer is used with the DFP17, AF17 Positioners or 4-75 Position Indicator when remote resistance indication is required.

The Dual Potentiometer is required when both AF17 or DFC 17 and 4-20 mA position output options are to be used together, one pot for each device.

Each pot can serve only one function. Remote resistance monitoring and an AF17, for example, cannot share a pot.

1. Adjusting Potentiometer:

NOTES: Potentiometers are adjusted at factory. If readjusting is necessary, follow instructions below.

Voltage limit of single pot or "B" pot of dual potentiometer is 30 volts maximum.

a. 10-3075 Actuator:

If not already installed, place the large face gear (12) over the actuator shaft with the gear teeth down and secure with snap ring (16) provided.

NOTE: The face gear utilizes a friction fit to the shaft. For best results, wipe off any lubricant that may be on the shaft before sliding on the face gear.

▲ CAUTION: Do not overstretch the snap ring, use the minimum opening to allow snap ring to slip over the gear.

- b. Adjust the potentiometer spur gear (8) until there is approximately 1/16" engagement with the large face gear. Tighten the spur gear set screw (9). If necessary, you can slightly bend potentiometer bracket to get proper engagement.
- c. Rotate the face gear back and forth to ensure smooth and easy operation of the potentiometer.
- d. Important: FOR 90° VALVES: With the actuator in the OPEN (full CCW) or CLOSED (full CW) position and power off, rotate the face gear, thus turning the potentiometer shaft until the resistance between the white/black lead (terminal 11) and the green lead (terminal 10) or the white/black lead (terminal 11) and the purple lead (terminal 12) respectively, as measured by an ohmmeter, is between 80 ohms and 90 ohms. (Refer to instruction sheets of options that may have different pot lead locations and adjustments, e.g., AF17 Positioner.)
- NOTE:** It is not necessary to loosen or remove face gear snap ring to rotate gear.
- e. Power the actuator to the opposite position from where resistance was measured.
- f. At this position, with power off, measure the resistance at the same terminals as stated above. The resistance reading should be greater than 700 ohms. If not, then power actuator back to original position and adjust pot again, if necessary, as stated in paragraph d. above. If unsuccessful in getting proper resistance readings, pot is defective and should be replaced.

The feedback potentiometer is now adjusted for use in the 75 actuator.

IMPORTANT: The feedback potentiometer is calibrated for only one 90° quadrant of valve operation. If the output shaft is repositioned to another 90° quadrant or if the output shaft is rotated on a multiple of 360° from its original position, the feedback potentiometer will no longer be in calibration and must be recalibrated.

Feedback Potentiometers

10-2375 Plan View

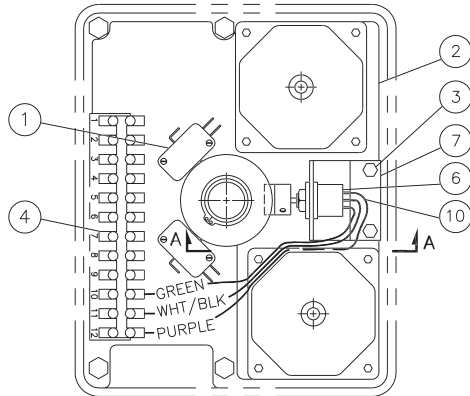

25/3075 Plan View

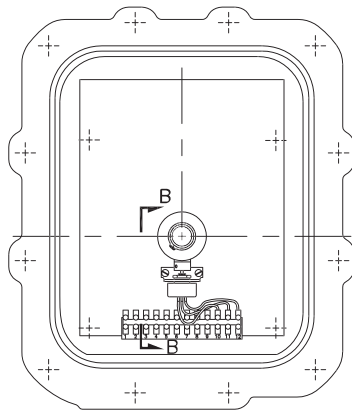

View A-A

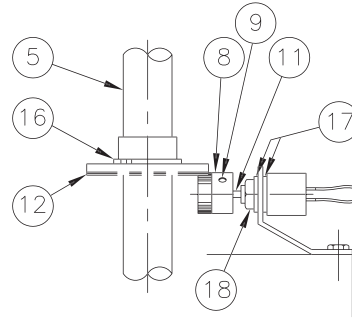

View B-B

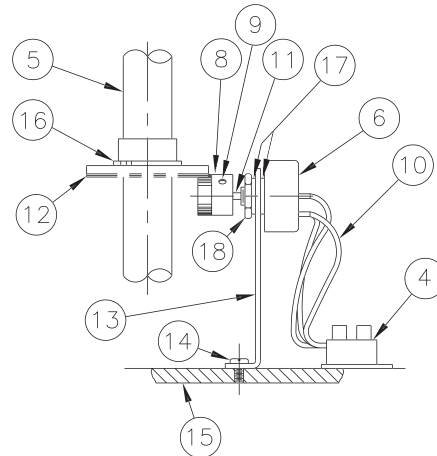

Item	Description
1	Limit Switches
2	Motor Module
3	Motor Module Mounting Screws (2)
4	Terminal Strip
5	Actuator Shaft
6	Potentiometer
7	Potentiometer Bracket
8	Spur Gear
9	Spur Gear Set Screw

Item	Description
10	Potentiometer Leads
11	Potentiometer Shaft
12	Face Gear
13	Potentiometer Bracket
14	Mounting Screws (2)
15	Motor Support Plate
16	Snap Ring
17	Lockwashers (2)
18	Nut

Illustrations show single potentiometer only.

25 and 3075

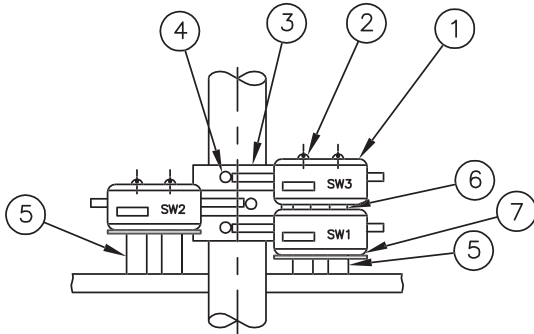

10-2375

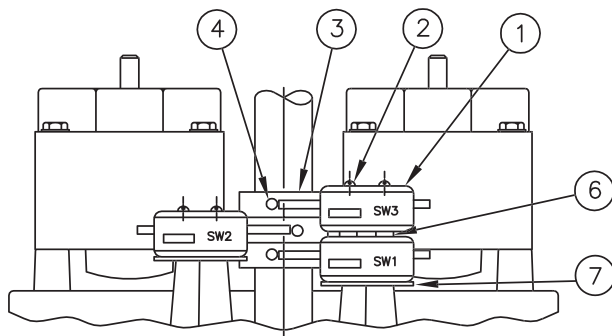

Typical Top View

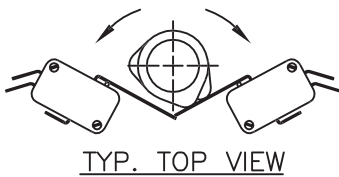

Item	Description
1	Extra Switch
2	#4-40 Screws (2)
3	Extra Cam
4	Set Screw (1)
5	Spacers (25/3075 Only)
6	Spacers (two per Switch)
7	Insulator

C. I-75 Interface

1. Description:

The I-75 Interface is designed to be used and mounted in the Series 75 Actuator as one of many standard options. Function of the I-75 Interface is to allow the Series 75 Actuator to be powered by a 120 or 240 VAC power supply, operated directly by any programmable controller, microprocessor, and/or computer regardless of output rating of these devices.

Depending on the control input used there are several options of the I-75 Interface:

5V for 5 VDC input, XV for 12 VDC input, XX for 24 VDC input, 15 for 120 VAC input.

These options are identified by the nameplate on the circuit board.

2. Indication and Repair:

LED Indicators – Light emitting diodes marked LD1, LD2 are in input circuits and indicating what particular input is on. Left, LD2, LED indicates that CCW, open, signal is on. Right, LD1, LED indicates that CW, close, signal is on.

If a malfunction occurs, look for the following:

If particular input is energized and corresponding LED light is not on, check for component damage or other continuity disruption in corresponding CCW and/or CW input circuit. If everything appears to be OK, replace matching opto-coupler U2 or U1.

Input circuit is OK. LED is lighted and actuator is not running. If components and continuity in corresponding power circuit are all right, then failed component is triac Q2 or Q1 depending which way the actuator doesn't run, CCW or CW.

If the actuator doesn't run in either direction, it is likely that the actuator is defective. To check this, remove the red and black leads from terminals 3 and 4 of the actuator (coming from Interface board) and the AC line connections from terminals 1 and 2. Tape these leads. Using a test cable, apply power to actuator terminals 1 and 3. The 120 VAC actuator only (see Note) should rotate CCW until stopped by the CCW limit switch. Then apply power to terminals 1 and 4 to check CW 120 VAC actuator and the CW limit switch. If the actuator does not operate, check 120 VAC associated wiring, terminal strip, the limit switches, motor, and capacitor. Check switch continuity. Check for an open motor winding, and check for a shorted capacitor. If the problem in the actuator still cannot be determined, return the unit for service. If the actuator functions properly, the problem is in interface board.

Request an RMA (Return Material Authorization) number from the service department, replace the defective board, and return it to the factory with proper description of problem and application.

NOTE: The limit switches for the 240 VAC I-75 actuator do not control the motor circuit, they control input circuit only. When applying power to terminals 1 and 3, and 1 and 4 to check CCW, CW rotations, do this momentarily so that you do not override 0-90° quadrant.

D. Extra Limit Switches (M1 or M2)

1. Setting:

NOTE: Switches and cams are set at factory. If resetting is necessary, use the following procedure:

- a. Bring actuator into position desired to actuate extra switch. Turn extra cam in direction of normal travel until switch just throws.
- b. Advance cam in same direction by 1–3° and secure cam by tightening the set screw (4).

For M2, a fourth switch (not shown) is added over SW2. The fourth cam (not shown) is positioned so that cam set screw faces terminal strip when cam is in contact with limit switch to give desired function. Cam lobe must approach switch lever from lever pivot end and not from free end—see Typical Top View on page 9. Follow setting instructions on last page.

E. Mechanical Brake (10-2375 Actuators)

NOTE: Mechanical brake should require no adjusting.

1. Testing and Troubleshooting:

- a. Energize actuator for rotation in both open and closed directions. At the rated actuator voltage, the brake coil is energized and moves the plunger to release brake arm. Clearance of .020" to .030" must exist between the brake arm and the brake disc when power is applied to the actuator.
- b. If the brake arm is too close to the brake disc, realign the coil housing so that coil plunger can move further toward the center of the actuator, permitting more movement of the brake arm.
- c. Plunger chattering indicates a low supply voltage. If actuator voltage is at the rated conditions, realign coil housing so that coil moves away from the center of the actuator to reduce plunger movement.
- d. All coil adjustment is done in small increments of .015 inches or less.
- e. Additional adjustment may be done by moving mounting plate toward/away from actuator shaft.
- f. Once proper operation of the brake is verified replace actuator cover.

10-23 75 Assembly Shown

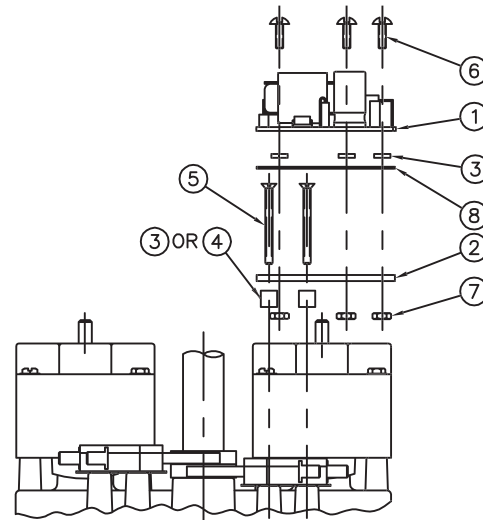

Item	Qty	Description
1	1	Circuit Board
2	1	Mounting Plate
3	5	Spacers (.06")
4	2	Spacers (.25")
5	2	Flat Head Screws
6	3	Head Screws
7	3	Nuts
8	1	Insulator
9	3	Cable Ties (Not Shown)
10	1	Potentiometer Kit (Not Shown)

F. Cycle Length Control (CLC Module)

CAUTION: CLC module must be used with proper line voltage.

Control of the actuator's cycle time is achieved by breaking up the power applied to the actuator into a series of pulses. The length of time a power pulse is applied is controlled by the "ON" adjustable control. The interval between pulses is controlled by the "OFF" adjustable control.

To adjust, start with both controls at midpoint. To reduce cycle time on 120 VAC units, turn "ON" control in CW direction and "OFF" control in CCW direction. To increase cycle time turn "ON" control in CCW direction and "OFF" in CW direction. To reduce cycle time on 240 VAC units, turn "ON" control in CCW direction and "OFF" control in CW direction. To increase cycle time turn "ON" control in CW direction and "OFF" in CCW direction.

IMPORTANT: If "ON" time adjustable control is at minimum and/or "OFF" time adjustable control is at maximum, the actuator will not rotate. The minimum "ON" pulse must allow the actuator to move a closed valve out of its seat. Verify proper CLC operation by opening a fully closed valve.



G. Heater and Thermostat

NOTE: Heater and thermostat option requires no adjusting. If defects are found, notify factory.

The thermostat will close/energize heater at ambient temperatures below 70°F.

H. Drain/Breather (V53) Option (10-2375 Actuators)

If actuator is equipped with drain/breather at bottom of base, actuator must be operated in an upright position for drain to operate properly.

I. 4-75 Position Indicator

1. Description:

The 4-75 position indicator is designed to be used and mounted with the standard Series 75 (Sizes 10-30), 120 VAC actuator, with many of its standard options. Its output is suited for 4-20 mA DC meter with 0-100% scale, which is not part of the package. If properly calibrated, it indicates actuator shaft position from close (0°, 0%) to open (90°, 100%).

It is combined with standard potentiometer, which supplies information on shaft position. If feedback potentiometer is required for other functions such as remote resistance indication or a DFC17 Controller, a dual potentiometer has to be used. Each potentiometer can serve only one function. See potentiometer kit instructions (Part No. 66-09750), available from your distributor/ supplier, for installation procedures, if necessary.

2. Adjustment and Calibration:

NOTE: If used with a DFC17 Controller, see DFC17 Installation, Operation and Maintenance manual (part no. 66-14946) for adjustment and calibration.

The feedback potentiometer has to be adjusted to obtain proper resistance range. With the actuator either in the OPEN (full CCW) or CLOSE (full CW) position, and power off, rotate the face gear, thus turning the potentiometer shaft, until the resistance between the white/black lead and the green lead (actuator full CCW) or the white/black lead and the purple lead (actuator full CW) respectively, as measured by ohmmeter, is between 80 ohms and 90 ohms.

NOTE: It is not necessary to loosen or remove face gear snap ring to rotate gear, it is a friction fit.

Power the actuator to the opposite position from where resistance was measured.

At this position, with power off, measure the resistance at the same terminals as stated above. The resistance reading should be greater than 700 ohms. If not, then power actuator back to original position and adjust pot again, if necessary, as stated in paragraph above. If unsuccessful in getting proper resistance readings, pot is defective and should be replaced.

To obtain proper 4-20 mA output, the indicator has to be calibrated. Using an ammeter, connected to actuator Terminals 5 (positive) and 6 (negative), adjust the two potentiometers R4 and R5 on the board. With the actuator in the closed position (0%), adjust R5 potentiometer (adjacent to the #4 etched on the circuit board and closest to terminal block) to obtain 4 mA on the ammeter. Move the actuator to the open position (100%) and adjust R4 potentiometer (adjacent to the #20 etched on the circuit board) to obtain 20 mA. Because adjustment of one potentiometer affects the other, repeat the procedure several times to obtain proper values.

IMPORTANT: The feedback potentiometer is calibrated for only one 90° quadrant of valve operation. If the output shaft is repositioned to another 90° quadrant or if the output shaft is rotated a multiple of 360° from its original position or the position indicator is removed from the actuator, the feedback potentiometer will no longer be in calibration and must be recalibrated.

3. Repair: In case factory repair is required, contact service department, and request an RMA (Return Material Authorization) number. After receiving new circuit board replace defective board and return it back to factory with description of problem and application.



Manual Operation

IMPORTANT: Disconnect actuator from power supply. If power is not off, motor will start when cam moves from limit switch.

- A. 10-2375 W, X and Z: Pull the declutching knob all the way up and hold. Apply wrench to exposed flats on actuator shaft and rotate to desired position. To reengage, return shaft to original position of disengagement and release declutch knob.
- B. 25-3075 Z: Simply turn manual override handwheel in the desired direction (clockwise rotation of handwheel causes actuator drive shaft to rotate clockwise, when viewed from above). The manual override can be used at any time without damaging the actuator.

NOTE: Actuator should be manually operated only over the range for which it is set up to operate electrically. Operation beyond this range will totally disrupt indexing.

Maintenance and Troubleshooting

The Series 75 electric valve actuator requires no regular maintenance. Should the unit fail to operate, however, the following are hints for troubleshooting. If the unit still fails to operate, consult the factory.

Electrical Supply Be sure the Series 75 is supplied with the correct voltage.

Electrical Connections Does the wiring conform to the wiring diagram?

Limit Switches If both switches are depressed simultaneously, the unit will not operate. Make sure the switches trip one at a time.

Capacitor The AC motors are operated with a capacitor. If the capacitor is defective, it will prevent the motor from starting and/or running. Replace if necessary. If capacitor has metal retaining ring, insulating fiber washer must be used.

Motor If one of the motor windings is open or short-circuited, the unit will not operate. If motor is hot, allow it to cool down so that the stator is at room temperature. Apply voltage to motor. If motor still fails to operate, replace entire motor module.

DC Motors DC motors use no thermostat and are therefore not protected against high temperatures and currents. Use of these motors above rated torques (loads) and/or duty cycle can cause permanent damage. If DC motor(s) fail(s) to operate under minimal torque loading, or if one of the two motors fail, replace entire motor module.

NOTE: Failure of one motor on dual DC motor module may mechanically damage the gear train.

Gear Train

10-2375 (All) Remove motor module from the actuator. Rotate the motor by hand. Spinning the motor shaft should rotate the module output pinion. If module output pinion fails to rotate, replace entire motor module. Also, check bull gear for missing or broken teeth. Replace if necessary.

25-3075 (All) Remove actuator from valve. Rotating the motor shaft manually should cause the actuator output shaft to rotate. If output shaft does not rotate, gearing has been damaged. Return actuator to factory for repair.

Valve The problem may lie with the valve instead of with the actuator. Check the operation of the valve by removing the actuator and operating the valve by hand.

Options For troubleshooting or adjustment of options, see Options and Adjustment section for individual options.

Spare Parts

The following are recommended spare parts which should be kept on hand for Series 75 electric actuators:

1 Limit Switch Kit

1 Capacitor (AC Units Only)

When ordering spare parts, please specify actuator size, voltage and cycle time.



Electrical Requirements

The following table represents approximate current draw (at rated stall torques) in amp at various voltages for each motor.

Actual values depend on several variables. For exact values, test the unit at a particular load.

Suffix Code	Duty Cycle	Voltage	Actuator Size							
			10	12	15	20	22	23	25	30
Blank	20%	120 AC	—	—	0.7	—	—	—	—	—
Blank	25%	120 AC	0.7	0.7	—	1.5	1.5	—	2.7	3.5
2	10%	120 AC	1.5	1.5	—	2.9	2.9	—	—	—
4	75%	120 AC	0.3	0.3	—	0.7	0.7	0.7	2.2	2.2
5	100%	120 AC	0.25	0.25	—	0.5	—	—	—	—
Blank	25%	240 AC	0.4	0.4	—	0.9	0.9	—	1.3	1.4
2	10%	240 AC	0.6	0.6	—	1.3	1.3	—	—	—
4	75%	240 AC	0.15	0.15	—	0.3	0.3	0.3	1.2	1.2
5	100%	240 AC	—	—	—	—	—	—	—	—
Blank	25%	12 DC	1.4	1.2	—	5	4.2	—	—	—
4	75%	12 DC	0.5	0.5	—	1.6	1.5	2	—	—
Blank	25%	24 DC	0.7	0.6	—	2.5	2.1	—	—	—
4	75%	24 DC	0.25	0.25	—	0.8	0.75	1	—	—

Cycle Time (sec.)

Suffix Code	10	12	15	20	22	23	25	30
Blank	5	8	5	5	8	—	10	15
2	2.5	4	—	2.5	4	—	—	—
4	17, 15	27, 25	—	17, 15	27, 25	25	15	23
5	17	27	—	27	—	—	—	—

If a heater is used on 12 or 24 VDC actuators, increase the locked rotor currents shown above by the following values (This applies to DC voltages only):

Locked Rotor Currents

	12 VDC	24 VDC
Heater	1.3 amp	0.7 amp

Electrical Schematics (Series 75)

(Actuator shown in counter-clockwise extreme of travel, or “open” position.)

NOTE: DC wiring diagram shown is for size 10, 20 and 23 actuators. For 12 and 22 sizes, the red/black motor leads are reversed.

For G.P. Actuators only, terminal 6 is used for ground connection and L2 should be wired directly to N.O. Terminal of SW-2.

AC

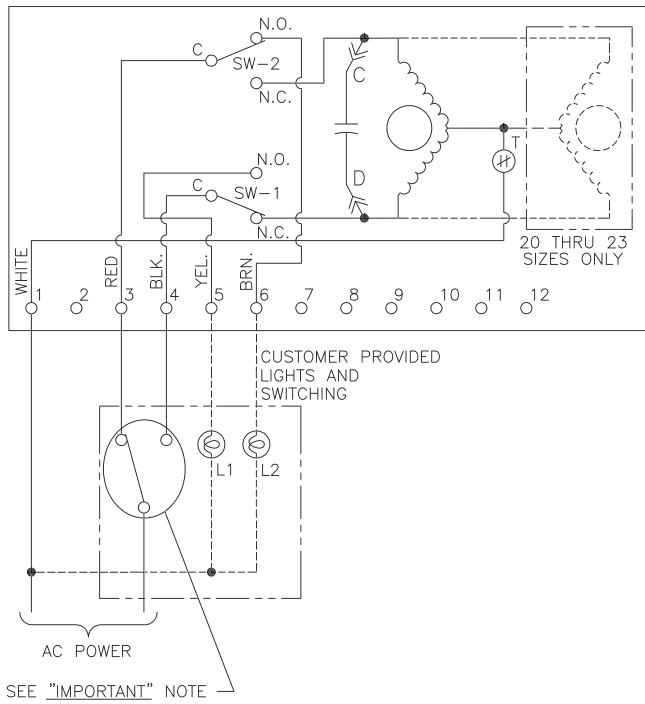

DC

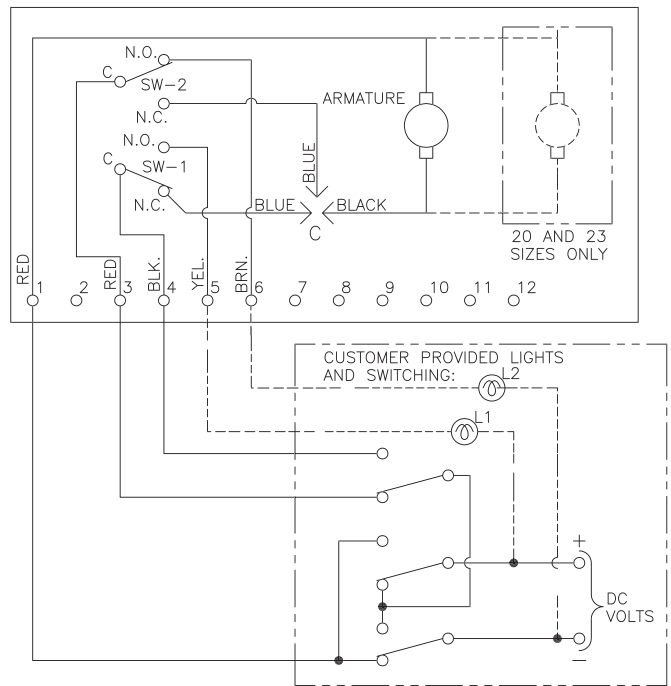

IMPORTANT: each actuator should be electrically powered through its own individual switch to isolate the unused winding.

Each motor has a “thermal protector” as shown by wiring of MB 75 option in diagram.

See table on page 5 for minimum fuse rating when overcurrent protection is used in motor power circuit.

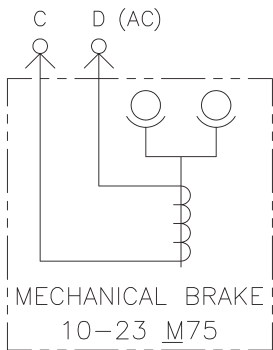

Electrical Schematics and Wiring Diagrams for Options (Series 75)

(For installation of options, refer to installation instructions and wiring diagram(s) contained in respective kit.)

NOTE: DC center-off wiring diagram as shown on page 17 is for size 12 and 22 actuators.

For 10, 20 and 23 sizes, the red/black motor leads are reversed.

General Schematic

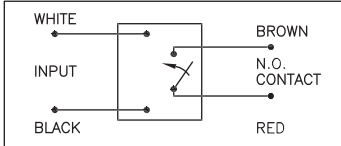

10-30 C 75 120A/240A C

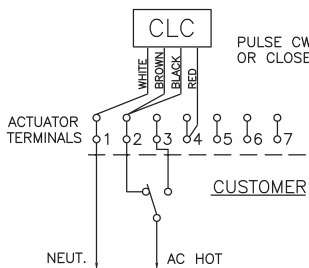

10-30 C 75 120A/240A O

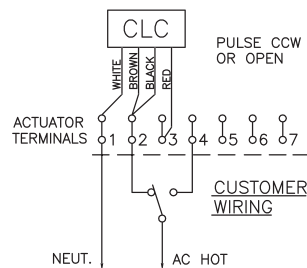

10-30 C 75 120A/240A

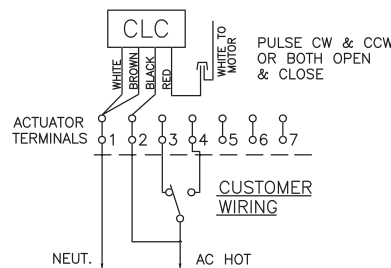

Wiring for 10-30 P/D 75 Feedback Pot Option

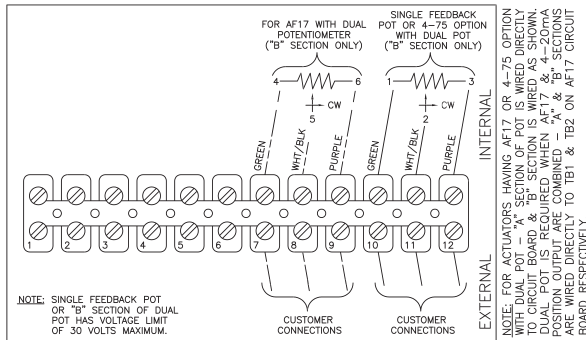

Wiring for 10-30 H75 Heater/Thermostat Option

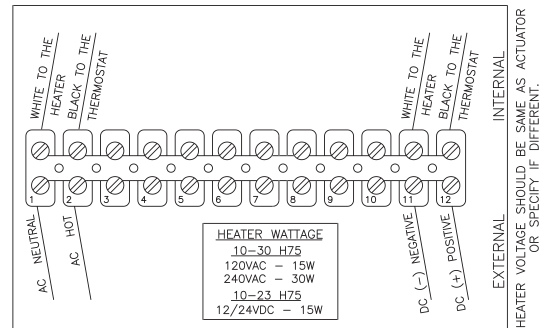

Wiring for 10-30 75 M1 Option (One Extra Limit Switch)

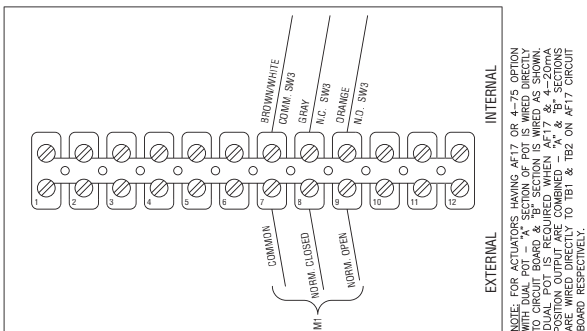

Wiring for 10-30 75 M2 Option (Two Extra Limit Switches)

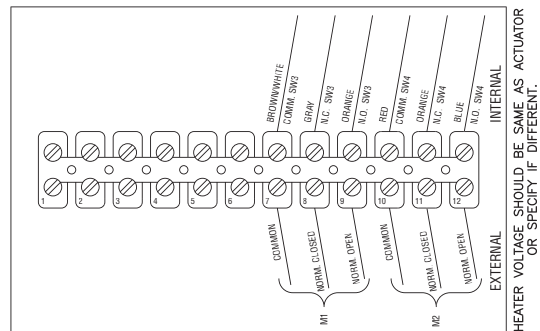

Series 75 AC Electric Actuator with Center-Off (D3) Option

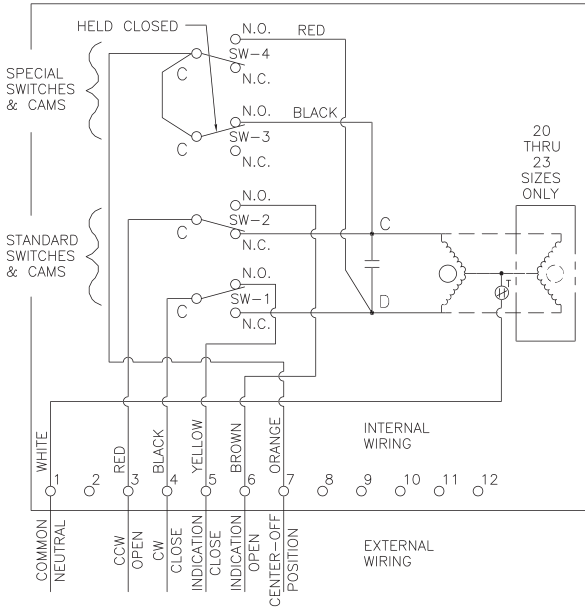

Series 75 DC Electric Actuator with Center-Off (D3) Option

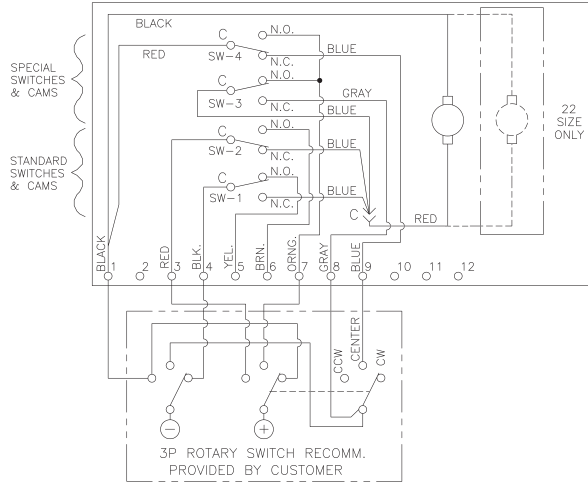

Wiring of I-75 240 VAC Interface

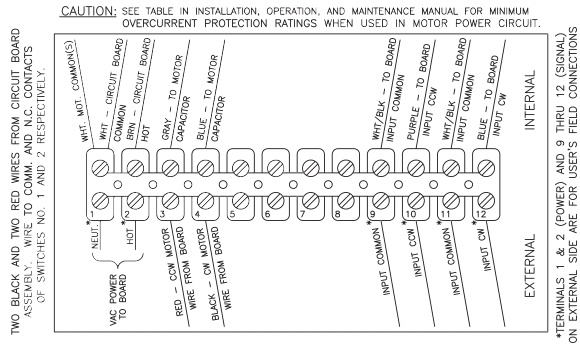

Wiring of I-75 120 VAC Interface

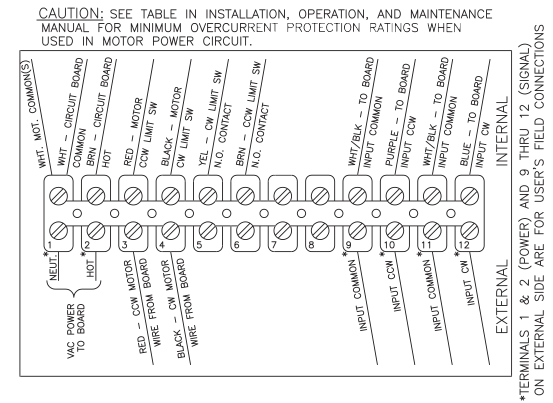

Wiring of 4-75 120 VAC Position Indicator

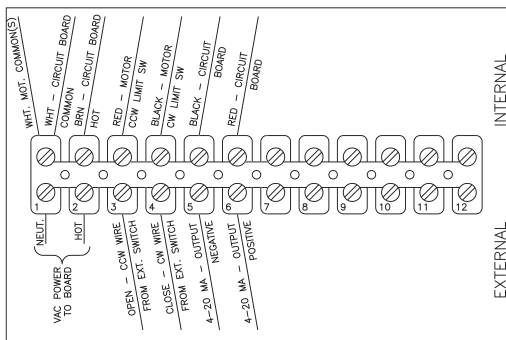

Parts List

Sizes 10-23

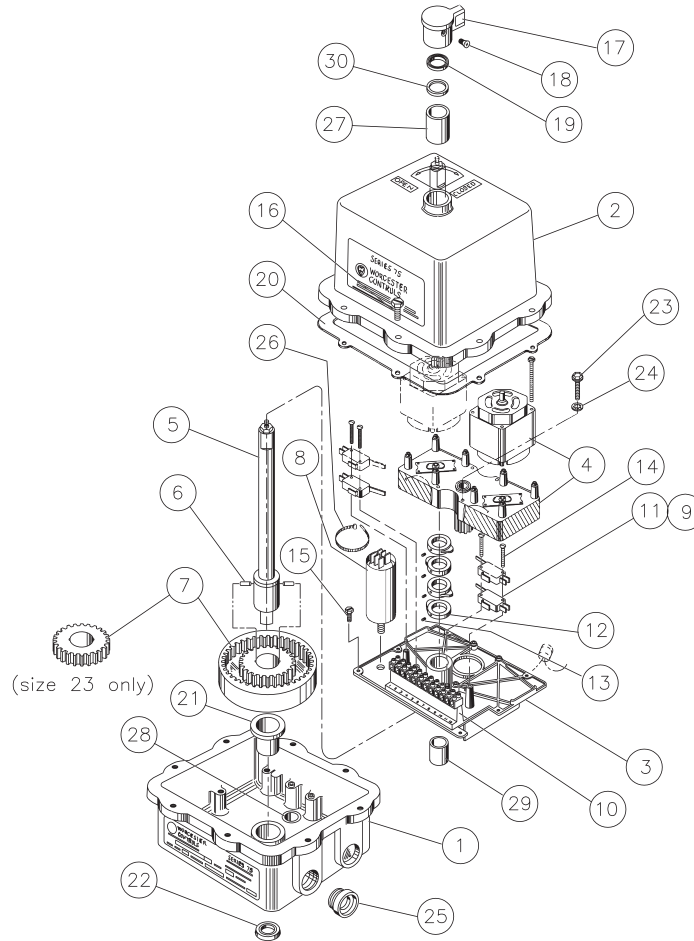

Note: Series 75 W is shown. Series 75 general purpose, X and Z units have different bases and covers.

Item	Qty	Description	Material
1	1	Base	Aluminum Casting
2	1	Cover	Aluminum Casting
3	1	Base Plate	Zinc Casting
4	1	Motor Module	Zinc Casting
5	1	Output Shaft	Steel
6	2	Gear Drive Pin	Steel
7	1	Bull Gear	Steel
8	1	Capacitor (Round or Rectangular Type)	Phenolic Encapsulated
9	2	Switch Insulator (not shown)	Nylon
10	1	Terminal Strip	Polyethylene Based Material
11	2	Limit Switch	Phenolic Encapsulated
12	2	Limit Switch Cam	Zinc Casting
13	1/Cam	Cam Set Screw	Steel
14	4	Limit Switch Screw	Steel
15	6	Base Plate Screw	Steel
16	8	Hex Screw (W, X, Z)	Stainless Steel

Item	Qty	Description	Material
16	4	Hex Screw (GP)	Steel
17	1	Position Indicator (W, X, Z)	Lexan
18	1	Indicator Set Screw (W, X, Z)	Steel
19	1	Seal (W, X, Z)	Reinforced Rubber
20	1	Gasket (W only)	Neoprene
20	1	Flange Seal (Z only)	Buna N
21	1	Bearing	Bronze
22	1	Seal	Reinforced Nitrile
23	4	Screw	Steel
24	4	Lock Washer	Steel
25	1	Conduit Plug	Polyethylene
26	1	Cap. Tie (for Rect. Cap. only)	Plastic
27	1	Bearing (W,X,Z)	Bronze
28	1	Roller Bearing (size 23 only)	Steel
29	1	Bearing, Base Plate	Nylon
30	1	"O" Ring (W,X,Z)	Buna

Sizes 25, 30

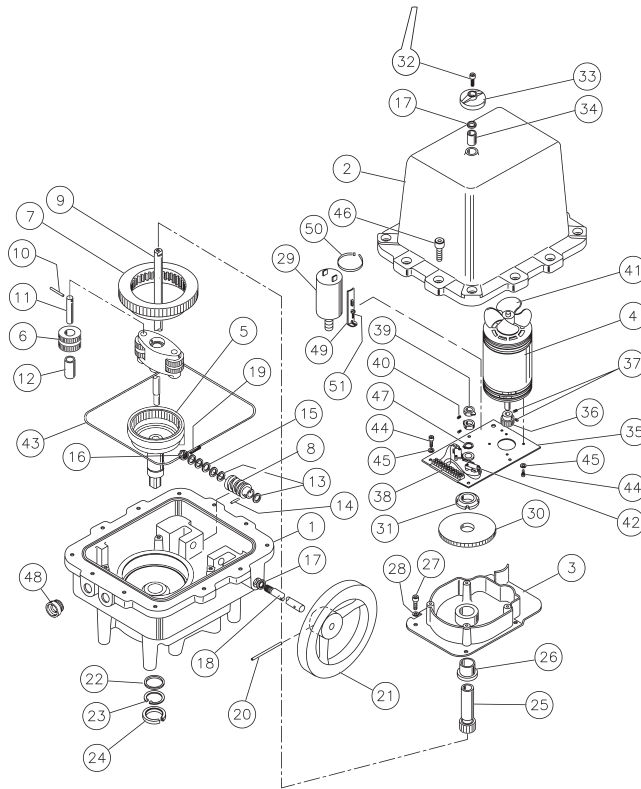

Item	Qty	Description	Material
1	1	Base	Aluminum
2	1	Cover	Aluminum
3	1	Gear Train Support	Aluminum
4	1	Motor	
5	1	Output Gear	Steel Casting
6	2	Planet Gear	Hardened Steel
7	1	Planetary Gear	Ductile Iron
8	1	Worm Gear	Steel
9	1	Sensing Shaft	Steel
10	2	Pin, Spring	Steel
11	2	Shaft	Hardened Steel
12	2	Bushing	Bronze
13	2	Thrust Washer	Steel
14	1	Pin, Spring	Steel
15	4	Belleville Washer	Steel
16	1	Nut	Steel
17	2	Seal	Rubber, Steel
18	1	Manual Override Shaft	Steel
19	1	Pin, Cotter	Steel
20	1	Pin, Spring	Steel
21	1	Handwheel, Manual Override	Aluminum
22	1	Thrust Washer	Steel
23	1	Tru-arc Ring	Steel
24	1	Seal	Rubber, Steel
25	1	Sun Gear	Steel
26	1	Bushing	Bronze

Item	Qty	Description	Material
27	4	Cap Screw	Steel
28	4	L Washer	Steel
29	1	Capacitor (Round or Rectangular type)	Phenolic Encapsulated
30	1	Input Gear	Steel
31	1	Nut	Steel
32	1	Cap Screw	Steel
33	1	Position Indicator	Aluminum
34	1	Bushing	Bronze
35	1	Motor Support Plate	Aluminum
36	1	Gear, Pinion	Steel
37	2	Set Screw	Steel
38	1	Terminal Strip	Polyethylene Based Material
39	2	Limit Switch Cam	Zinc Casting
40	1/Cam	Cam Set Screw	Steel
41	1	Fan	Plastic
42	2	Limit Switches	Phenolic Encapsulated
43	1	"O" Ring	Buna
44	9	Cap Screw	Steel
45	9	Lock Washer	Steel
46	12	Cap Screw	Steel
47	1	Sensing Shaft Ret. Ring	Steel
48	1	Conduit Plug	Polyethylene
49	1	Cap. Bracket (for Rect. Cap. only)	Steel
51	1	Cap. Bracket Screw (for Rect. Cap.)	Steel

[Visit www.boighill.com to request a quote.](http://www.boighill.com)



United States

Flowserve Corp.
Flow Control
Flowserve Worcester Actuation
Systems
5114 Woodall Road
P.O. Box 11318
Lynchburg, VA 24506-1318 USA
Phone: 1 434 528 4400
Fax: 1 434 845 9736

FCD WCAIM2013-01 Printed in USA. (Replaces IOM-12156)

To find your local Flowserve representative:

For more information about Flowserve Corporation, visit
www.flowserve.com or call USA 1 800 225 6989

Flowserve Corporation has established industry leadership in the design and manufacture of its products. When properly selected, this Flowserve product is designed to perform its intended function safely during its useful life. However, the purchaser or user of Flowserve products should be aware that Flowserve products might be used in numerous applications under a wide variety of industrial service conditions. Although Flowserve can (and often does) provide general guidelines, it cannot provide specific data and warnings for all possible applications. The purchaser/user must therefore assume the ultimate responsibility for the proper sizing and selection, installation, operation, and maintenance of Flowserve products. The purchaser/user should read and understand the Installation Operation Maintenance (IOM) instructions included with the product, and train its employees and contractors in the safe use of Flowserve products in connection with the specific application.

While the information and specifications contained in this literature are believed to be accurate, they are supplied for informative purposes only and should not be considered certified or as a guarantee of satisfactory results by reliance thereon. Nothing contained herein is to be construed as a warranty or guarantee, express or implied, regarding any matter with respect to this product. Because Flowserve is continually improving and upgrading its product design, the specifications, dimensions and information contained herein are subject to change without notice. Should any question arise concerning these provisions, the purchaser/user should contact Flowserve Corporation at any one of its worldwide operations or offices.

© 2004 Flowserve Corporation, Irving, Texas, USA. Flowserve is a registered trademark of Flowserve Corporation.

flowserve.com

[Visit www.boighill.com to request a quote.](http://www.boighill.com)