



Worcester Controls

Metal Characterized-seated Control Valve

1/4" – 4" CPT 44 and 1/2" – 4" CPT 51/52

Installation, Operation and Maintenance Instructions

CAUTION: Flowserve recommends that all products which must be stored prior to installation be stored indoors, in an environment suitable for human occupancy. Do not store product in areas where exposure to relative humidity above 85%, acid or alkali fumes, radiation above normal background, ultraviolet light, or temperatures above 120°F or below 40°F may occur. Do not store within 50 feet of any source of ozone.

A. INSTALLATION

1. Valve is designed for flow in either direction. Use care to exclude pipe sealants from valve cavity.
2. When installing CPT 44 or CPT 51/52 flanged valves, use standard gaskets suitable for the specific service and tighten the flange bolts or studs evenly. On CPT 44 wafer valves it is recommended to leave the ball in the open position while installing, to eliminate possibility of damaging ball finish.
3. CPT 44 Weld End Valves (SW, BW):

NOTES: Prior to welding, THOROUGHLY CLEAN ALL JOINT SURFACES to prevent contamination.

Valves with "AG", "GG", "PG", "RG", and "XG" seat/body seal combinations and V67 option code are compatible with welding temperatures. Therefore, these valves are weld-as-is and do not have to be disassembled to be welded in line. These valves will have a red welding tag attached. If these valves are disassembled, the graphite coated stainless steel gasket body seals (code "G"), and the seat back seals (used with "A" or "G" seats only) must be replaced. When welding these valves, the valve must be open to prevent adhesion of weld spatter to the ball. Use STICK or MIG welding, and allow valve and joint to cool to the touch between passes.

For All Other Weld End Valves:

- a. Tack weld the valve in place.
- b. Remove actuator and all four body nuts and bolts and place the valve in the open position.
- c. Remove center section from between pipe ends by separating the pipe ends from the body by at least 1/8" to allow locating diameter on the back of the metal characterized seat (inserted into oversized pipe end bore) to clear pipe end flange.

- d. With valve in closed position, remove seats, seat back seal(s), body seals and ball. Return the body to its original position and temporarily secure it with two bolts diagonally opposite each other.
- e. Weld valve in line. If gas welding is used, do not play flame on valve body.
- f. Allow valve to cool. Remove body and, with stem in the closed position, replace ball, seats and install new seat back seal(s), which are shipped separately from valve. Do not reuse old seat back seal(s). The characterized seat has a "V" or "Slot" cut in it for improved flow control, and must be properly oriented to function. A locating pin is provided in the body, and a groove in the seat, to assure that proper alignment is accomplished. The seat must fit properly and not jam on the pin. The opposite seat has a standard round port in it.
- g. Open the valve and replace body seals, or add new body seals, if they were shipped separately from the valve. Temporary Buna body seals, if found in the valve as received, are not to be reused. (If coated stainless steel "S" gasket body seals are used [Code M or G], install them with wide flange facing the body [see view A-A on page 6]). Before putting the center section between the pipe ends, make sure that the seat back seal is centered on the back of the seat. If it is not, it could be damaged or cause the valve to leak.
- h. Place center section between pipe ends by separating the pipe ends from the body by at least 1/8" to allow locating diameter on the back of the metal characterized seat (for insertion into oversized pipe end bore) to clear pipe end flange. Replace actuator and body bolts and nuts. Tighten and torque the body bolts evenly and diagonally opposite each other, alternating in a criss-cross pattern to the following torque figures:

Carbon Steel Bolts			Stainless Steel and Alloy 20 Bolts		
Bolt Diameter	in-lb	ft-lb	Bolt Diameter	in-lb	ft-lb
1/4"	96-120	8-10	1/4"	72-94	6-8
5/16"	156-204	13-17	5/16"	120-144	10-12
3/8"	216-264	18-22	3/8"	192-216	16-18
7/16"	480-540	40-45	7/16"	336-384	28-32
1/2"	720-780	60-65	1/2"	504-552	42-46

NOTE: Stainless steel bolts and nuts are used in all three-piece valves with stainless steel bodies and also valves with "GG" seats and body seals.

4. CAUTION:

- a. The seat back seals, fluoropolymer body seals (T), and the coated stainless steel gasket body seals (M and G) are not reusable. Upon disassembly of the valve these seals must be replaced. Also ensure that the fluoropolymer seals, or the coating of the stainless steel gaskets is not scratched or damaged during installation. Light lubrication of these seals can help to prevent damage.
- b. Care must also be taken when handling graphite thrust bearings, stem seals or seat back seals. These parts can be easily damaged by squeezing the O.D. of the seal. Parts are to be handled on the flat surfaces rather than the O.D.
- c. The ball used in CPT valves is round to special tolerances to ensure proper contact with the seat. Do not drop, dent or scratch the ball during handling. The ball also has a special anti-galling coating; DO NOT use an uncoated ball in CPT valves.

B. OPERATION

1. The operation consists of turning the stem 1/4 turn clockwise to close and 1/4 turn counter-clockwise to open. When stem flats (1/4" – 2") or stem groove (3", 4") are in line with the pipeline, the valve is open. This valve is designed to be automated.
2. CPT valves meet the leakage rates of ANSI B16.104 Class VI.
3. As shipped from the factory, valves contain a silicone-based lubricant. This is for break-in purposes. Lubricant may be removed with a solvent, such as lacquer thinner, if found to be objectionable for a particular application, and replaced with a non-silicone based lubricant. CPT valves should not be operated without a break-in lubricant.
4. Media which can solidify, crystallize or polymerize should not be allowed to stand in valve cavities.
5. *Torque Requirements:* Operating torque requirements will vary depending on the length of time between cycles, line pressure, type of valve seats, and the media in the system. All figures in the following table are based in laboratory tests with water as the media. They are measured at WOG rated pressure, 70°F, with clean tap water, after 24 hours. For a more detailed analysis of valve torque requirements, see Worcester's Actuator Sizing Manual.

Valve Size	Maximum Expected Breakaway Torque
1/4", 1/2"	150 in-lb
3/4"	175 in-lb
1"	250 in-lb
1 1/2"	400 in-lb
2"	700 in-lb
3"	1900 in-lb
4"	3300 in-lb

C. MAINTENANCE

1. For 3"– 4" CPT 44/51/52 Revision RO-R2 valves, if seepage is noted at stem, tighten retaining nut 1/6 turn at a time until seepage stops.
2. Tighten stem seal retaining nut (1/2"– 2" CPT 44 Revision RO valves) or self-locking stem nut (1/4"– 2" CPT 44 & 1/2"– 2" CPT 51/52 Revision R1-R4 valves) if seepage is noted at stem.

CAUTION: For maximum stem seal life, proper stem adjustment procedures must be followed. Excessive tightening causes higher torque and shorter stem seal life.

Revision RO Valves:

- a. Loosen top retaining nut.
- b. While holding the stem to prevent turning, tighten bottom-retaining nut until Belleville washers are flat (the nut will bottom).
- c. Back off bottom retaining nut 1/6 turn.
- d. Tighten the top retaining nut securely to lock the bottom retaining nut in place with the lockwasher in between. Hold the bottom nut securely with wrench while tightening the top nut to lock the two nuts in place.

Revision R1 -R4 Valves:

- e. Tighten self-locking stem nut until Bellevilles washers are flat, then back off nut 1/3 turn.

CAUTION: The self-locking stem nut is difficult to tighten, and must fully flatten Bellevilles before backing off.

D. REBUILDING

▲ WARNING: - BALL VALVES CAN TRAP PRESSURIZED FLUIDS IN THE BALL CAVITY WHEN CLOSED.

If the valve has been used to handle hazardous media, it must be decontaminated before disassembly. It is recommended that the following steps be taken for safe removal and disassembly.

- Relieve the line pressure. Operate the valve prior to attempting removal from line.
- Place the valve in half-open position and flush the line to remove any hazardous material from the valve body.
- All persons involved in the removal and disassembly of the valve should wear the proper protective clothing such as a face shield, gloves, apron, etc.

1. A standard repair kit can be ordered for these valves consisting of seats, control seat or control seat insert (3"– 6" valves only), body seal(s), seat seal(s), Belleville washers, stem seal(s), thrust bearing(s), and a self-locking stem nut (1/4"– 2" Revision R1-R4 valves only). Specify the valve size and series, the material of the seat and body seal, the characterized seat configuration (if needed), and the "R" number (Revision Number) of the valve or for non-standard valve, the "P" number, "T" number, "C" number, or similar, as found on either the mounting bracket nameplate or the valve nameplate.

CAUTION: If the seats and seals installed differ from those removed, the valve nameplate must be replaced or remarked to indicate the altered materials and ratings, or valve tagged to so indicate.

2. To Disassemble 1/4"– 2" CPT 44 Valves (All Revisions):

- a. Remove actuator and all four body nuts and bolts, and place the valve in the open position.
- b. Remove center section from between pipe ends by separating the pipe ends from the body by at least 1/8" to allow locating diameter on the back of the metal characterized seat (inserted into oversized pipe end bore) to clear pipe end flange.
- c. With valve in closed position, remove old seats, seat back seal(s), body seals and ball.
- d. Revision RO Valves: Using a wrench to prevent stem from turning, remove top retaining nut, lockwasher, bottom retaining nut, and (2) Belleville washers from stem.

Revision R1-R4 Valves: Using a wrench to prevent stem from turning, remove self-locking stem nut, and (4) Belleville washers from stem.

- e. Remove the follower, stem, stem seal(s), stem seal protector (if any), thrust bearing, and thrust bearing protector (if any), which may be on the stem or in the body cavity. Retain the follower.

To Disassemble 1/2"– 2" CPT 51/52 Valves (All Revisions):

- f. Remove actuator from valve. Remove valve from line. Unscrew end plug and set aside. If the body seal was not removed with the end plug, remove it from the body and discard. Also remove the near seat and seat back seal, if applicable. Place valve in closed position and remove the ball, the far seat and seat seal.

NOTE: If required, end plug removal tools are available from your supplier or from your Worcester representative.

- g. Using a wrench to prevent stem from turning, remove self-locking stem nut, and (4) Belleville washers from stem.

NOTE: On the 1/2" valve, the far seat must be removed before pushing stem into cavity.

- h. Remove the follower, stem, stem seal(s), stem seal protector (if any), and thrust bearing, and thrust bearing protector (if any), which may be on the stem or in the body cavity. Retain the follower.

To Disassemble 3"– 4" CPT 44/51/52 Valves (All Revisions):

- i. Remove actuator from valve. Unscrew all flange bolts and nuts and remove valve from line. Remove all end plug retaining set screws from the valve body. Remove end plug. If necessary, drive end plug from the valve using a wooden drift applied to the ball. If the body seal was not removed with the end plug, remove it

from the body and discard. Also remove the near seat and seat back seal (if any). Place valve in closed position and remove the ball, the far seat, seat insert (if used), and seat back seal.

General Note: Due to different valve series and body styles, one or two metal stem centering washers may be used and the stem seal may be one-piece or three-piece, and may include a stem seal protector.

- j. Prevent the stem from turning by holding inside body. (The ball can be inserted and prevented from rotating with a non-metallic rod such as a screwdriver handle.) This will hold the stem stationary without damaging the ball. Remove retaining nut and stem spacer (if used).

- k. Remove Belleville washers (if any). Remove and retain the follower and push stem into ball cavity and remove. Discard old stem seal protector (if any), stem seal(s) and thrust bearing, which may be stuck on the stem or in the body cavity. Remove stem-centering washer(s) and retain.

3. Visual Inspection:

- a. As noted in part A.4.c, the ball is round to special tolerances and should be visually checked for defects. Light marring from the action of the ball against the seats is normal and will not affect the operation of the valve. Visible tracking is normal. Tracking which can be felt is a potential problem.
- b. The stem and body surfaces that the thrust bearing and stem seal contact should be clean, undamaged, and free of pit marks and scratches.

4. Reassembly:

NOTE: For all valves, lightly lubricate the ball, seats, seat back seal(s), body seal(s), stem seal(s), and thrust bearing(s) with a lubricant compatible with the media and temperature being handled. White petroleum jelly is a good general-purpose lubricant.

When a repair kit is purchased, the seats will be lubricated at the factory. If they are not, they should be lubricated as noted in Paragraph D.4. and B.3. DO NOT operate a newly rebuilt valve without break-in lubricant. The seat back seals will be pre-assembled to the seat backs.

If graphite parts are used, handle them gently on the flat surfaces rather than the O.D. These parts can be easily damaged by squeezing the O.D. These parts will not work if they are cracked or broken. Light flaking of the material is acceptable.

For stem area rebuilding of all CPT valves, refer to exploded views, stem build illustrations, and stem component color chart on the following pages that pertain to the particular valve being rebuilt. Please note that PEEK thrust bearing and stem seal protectors are placed outside of seals and bearings. The seals and bearings must contact the body.

Repair Kit Order Example

1"	CPT	RK	44	GG	G60	R1 or T0914
(Size)	(Valve Series)	(Repair Kit)	(Valve Type)	(Seat, Seal)	(Characterized Seat Configuration)	(Revision # or P, T, C, etc., #)
					Not Used with 1/2"– 2" CPT 44 Revision RO Valves	

1/4"– 2" CPT 44 Valves:

Revision R0 Valves:

- a. Place new thrust bearing on stem and insert through body cavity. The stem seal is generally thicker than the thrust bearing.
- b. Place new stem seal, new stem seal protector of PEEK material (only if valve has High-per Fill ("X") seat on one end), follower and (2) new Belleville washers, with outer edges touching, on stem. If the stem seal does not easily go down over stem or into the body, use the follower to gently push the seal down.
- c. Place bottom retaining nut on stem and, using a wrench to prevent rotation, tighten retaining nuts as noted in Paragraph C (Maintenance). Excessive tightening causes higher torque and shorter seal life. For graphite stem trim, tighten retaining nut to 35 inch pounds, do not bottom.

Revision R1-R4 Valves:

- d. Place a new PEEK thrust bearing protector (except for Revision R1 valves) and a new thrust bearing on the stem and insert assembly through body cavity. Place a single new thick stem seal or a new thin stem seal and a new thick stem seal, depending on seat material, a new stem seal protector, and the follower in position. Stem seals, stem seal/thrust bearing protectors and thrust bearings that are the same size and color are generally interchangeable.
- e. Add (4) new Belleville washers (two pairs of Belleville washers must have the larger diameter sides touching each other).
- f. Place the self-locking stem nut on stem and, using a wrench to prevent stem from turning, tighten as noted in Paragraph C (Maintenance).

Revision R0-R4 Valves:

- g. With the valve in the closed position (stem flats going across pipeline), replace ball, seats and seat back seal(s) (used with "A" or "G" filled metal seats only). The characterized seat has a "V" or "Slot" cut in it for improved flow control. It must be properly oriented to function and the seat can only fit in the pipe end with an oversized port hole. A locating pin is provided in the body and a groove in the seat to assure that proper alignment is accomplished. This valve seat can only be assembled one way and must fit properly, not jam, on the pin. The opposite seat has a standard round port in it.
- h. Open the valve and add body seals (if coated stainless steel "S" gasket body seals are used, install them with wide flange facing the body. See View A-A on page 6). Before putting the center section between the pipe ends, make sure that the seat back seal is located on the seat correctly. If it is not, it could be damaged or cause the valve to leak.
- i. Place center section between pipe ends by separating the pipe ends from the body by at least 1/8" to allow locating diameter on the back of the metal characterized seat (for insertion into oversized pipe end bore) to clear pipe end and flange. Replace actuator and body bolts and evenly tighten and torque the body bolts to the figures in Paragraph A.3.h.

1/2"– 2" CPT 51/52 Valves (All Revisions):

- j. On all sizes except the 1/2", insert far (characterized) seat and seat back seal. The seat has a "V" or "Slot" cut in it for improved flow control, and must be properly oriented to function. A locating pin is provided in the body, and a groove in the seat, to assure that proper alignment is accomplished. This valve seat can only be assembled one way and must fit properly, not jam, on the pin. The seat should appear to sit flat into the back of the cavity indicating that the seat back seal is properly located on the seat. If the seat back seal is not correctly positioned, it could be damaged or cause the valve to leak.
- k. Place a new PEEK thrust bearing protector and a new thrust bearing on the stem and insert assembly through body cavity. Place a single new thick stem seal or a new thin stem seal and a new thick stem seal, depending on seat material, a new PEEK stem seal protector, and the follower in position. Stem seals, stem seal/thrust bearing protector and thrust bearings that are the same size and color are generally interchangeable.
- l. Add (4) new Belleville washers (two pairs of Belleville washers must have the larger diameter sides touching each other).
- m. Place the self-locking stem nut on stem, and using a wrench to prevent stem from turning, tighten as noted in Paragraph C (Maintenance).
- n. (Insert the far [characterized] seat and seat back seal into 1/2" valves per Paragraph j.)
- o. With valve closed, install ball, opposite seat, seat back seal (used with "A" or "G" filled metal seats only) and body seal (if coated stainless steel "S" gasket body seal is used, install it with wide flange facing center of valve. See View A-A on page 6). The opposite seat has a standard round port in it.
- p. Install end plug into body until body and end plug are metal to metal. The end plug may project up to .009" beyond surrounding serrated surface. End plug must be fully tightened against machined step in body. If in doubt, assemble end plug without seat and seal, make a witness mark and reassemble the full assembly.

3"– 4" CPT 44/51/52 Valves (All Revisions):

- q. Assemble the far (characterized) seat insert and seat (A or G filled metal), or for Revision R2 and later valves only, one-piece characterized seat, and seat back seal into the body cavity. The one-piece characterized seat or seat insert has a "V" cut in it for improved flow control and must be properly oriented to function. To assure that proper alignment is accomplished, Revision R0-R1 valves have a locating pin provided in the body cavity, and a groove in the seat insert. This valve seat insert can only be assembled one way and must fit properly, not jam, on the pin. For Revision R2 and later valves, the one-piece seat has a locating nib that aligns with a groove in the body cavity. The seat should appear to sit flat into the back of the cavity indicating that the seat back seal is properly located on the seat. If the seat back seal is not correctly positioned it could be damaged or cause the valve to leak.
- r. Reinstall stem centering washer(s) into the recesses in the body. When only one washer is used, it goes inside recess on top of the body and under the stem seal(s).

- s. Place new thrust bearing onto stem and insert through body cavity. The thrust bearing can be distinguished from the stem seals by the darker color of the 25% filled fluoropolymer used in the thrust bearing. A graphite stem seal which is metallic silver gray in color is larger than the thrust bearing. Stem seals and thrust bearings of the same size and color are generally interchangeable.
- t. Assemble new stem seal(s) over the top of the stem and down into the recess in the top of the body. For Revision R1 and R2 valves only, install a new PEEK stem seal protector over stem seals. The follower is assembled on top of the stem seal(s). If the stem seal does not easily seat into the body recess, use the follower to gently push it in place. Place spacer onto the valve stem. For valves with graphite stem seal and all Revision R1 and R2 valves, add two Belleville washers with large diameter sides touching each other and do not use stem spacer.
- u. Place retaining nut on stem. Using a wrench to prevent rotation, tighten retaining nut to fully compress packing, then back off 1/6 turn. Excessive tightening causes higher torque and shorter stem seal life. For graphite stem trim, tighten retaining nut to fully flatten Bellevilles, then back nut off 1/6 turn.
- v. With the valve in the closed position (stem groove going across pipeline), place ball inside the body cavity engaging the stem slot. Assemble body seal into its recess in the body making sure that it is seated properly. (Caution: If the body seal is installed on

the end plug, it will be damaged.) Assemble round port seat and seat back seal (used with "A" or "G" filled metal seats only) into the seat recess of the end plug. Then slide the end plug into the body as far as it will go.

- w. Finally, secure end plug in place by threading in the end plug retaining set screws, and tightening each one firmly. Proper installation will allow not more than .010" protrusion of the end plug beyond the valve body.

Upon reinstallation of the valve in the line, retighten the end plug retaining screws after the flange bolts are fully torqued up.

After the valve is assembled, it should be cycled a few times to ensure that the valve operates smoothly with no chattering of the ball. The normal operation is an initial high torque to "break" from the closed position to a smooth running lower torque mid-cycle, to a high torque at the end of the 90° cycle or open position. The torque is similar when closing.

When ordering parts, please provide the part name and the following information from the valve nameplate or mounting bracket nameplate: Valve Size, Style and Revision Number, e.g., 1/2" CPT 44 46 GG SE G30 R1 Ball; or for non-standard product, valve size and "P" number, "T" number, "C" number, or similar e.g., 1" CPT 44 66 XG SW A30 T0726 Stem.

The terminology shown in the following exploded view parts listings is standard.

3" and 4" 150# and 300# Flanged Construction 3" and 4" 151/301 Wafer Construction

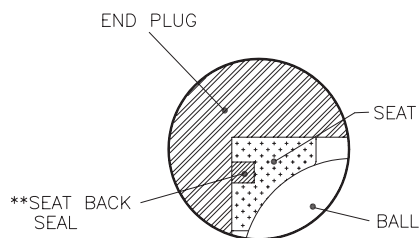

NOTE:

Flanged valve is shown. For wafer valve, disassembly is exactly the same.
 *This washer is not used on all valve styles. Reuse existing washer when present.
 **Used with "A" or "G" seats only.

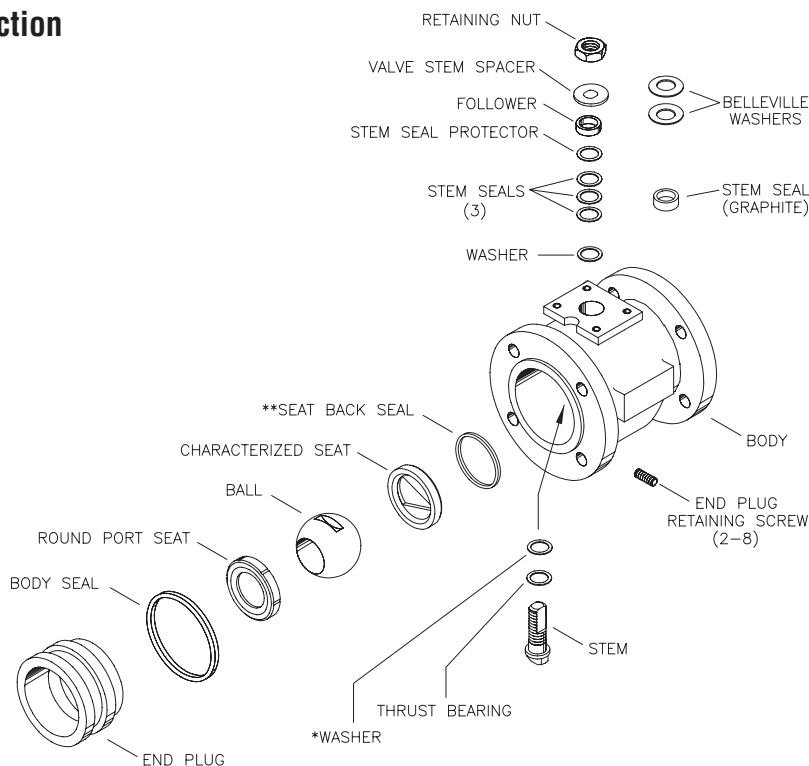

1/4"-2" CPT 44
(1 1/2" and 2" size valves shown)

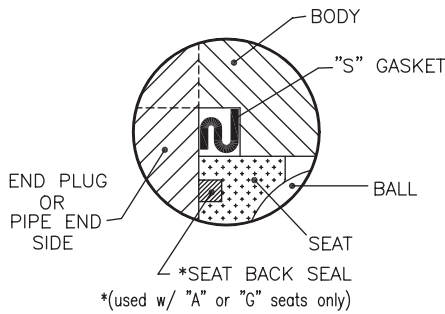
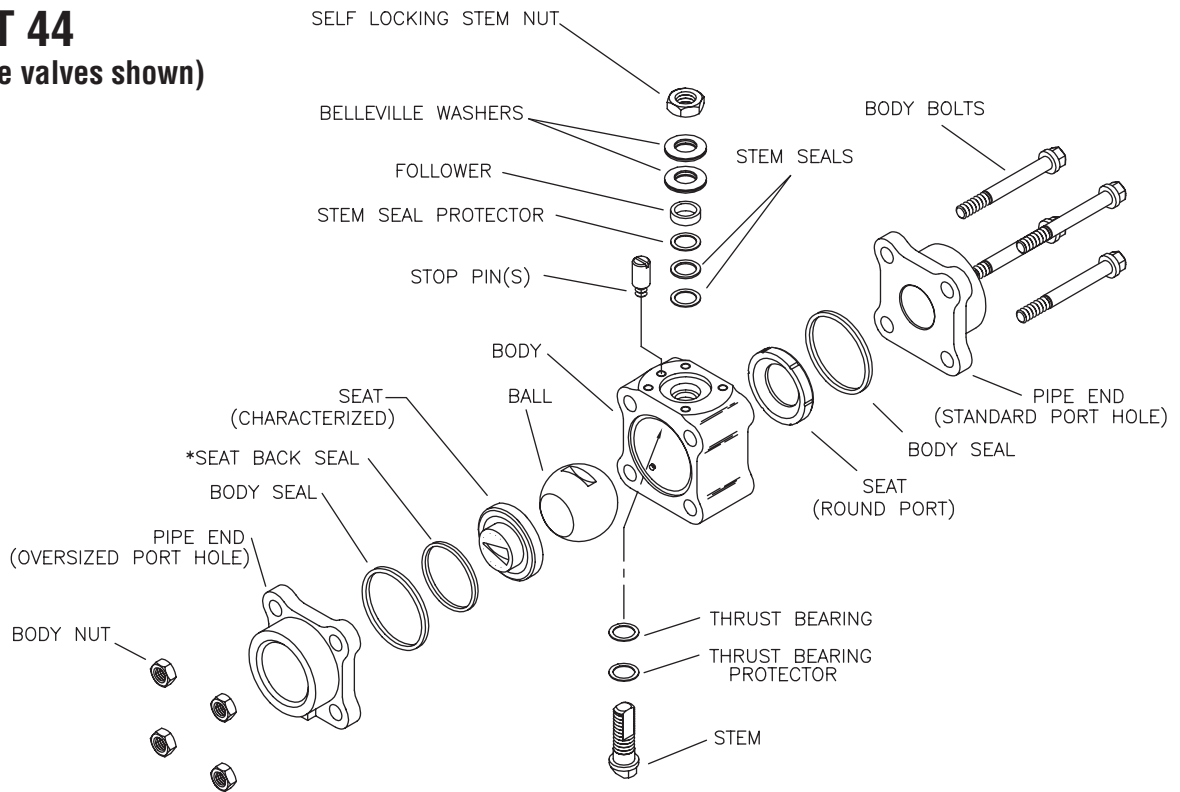

View A-A

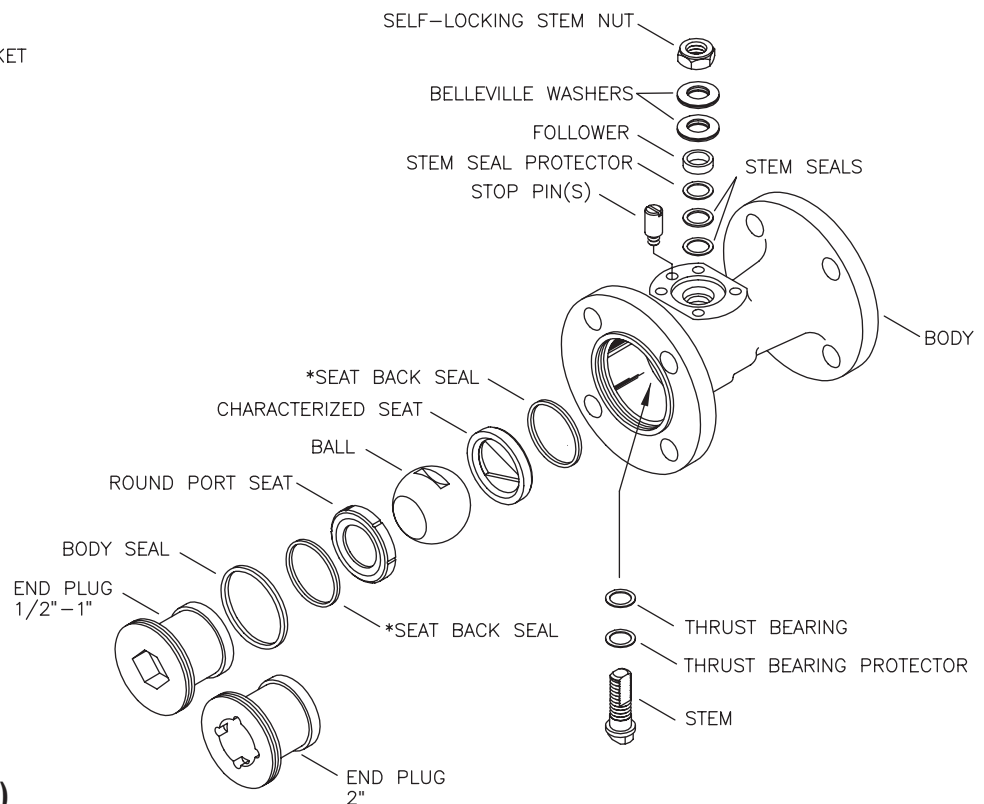

1/2"-2" CPT 51/52
(1 1/2" and 2" size valves shown)

1/4"-2" CPT Valve Stem Builds

Revision R2-R4 Valves with A, G, P, R or T Seat

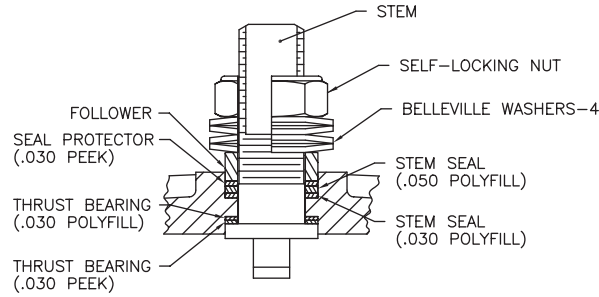

Revision R2-R4 Valves with High-per Fill X Seat

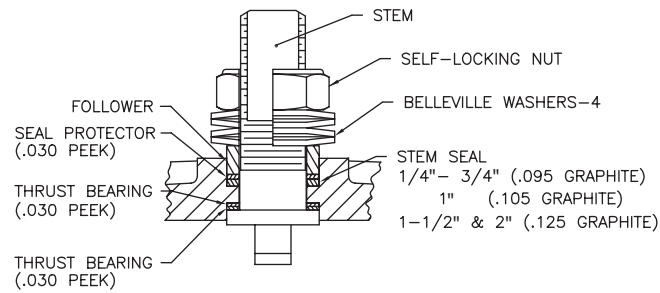

Revision R1 Valve with G, P, T or X Seat

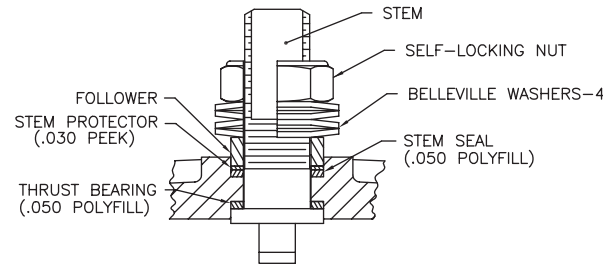

Revision R1 Valve with UHMWPE U Seat

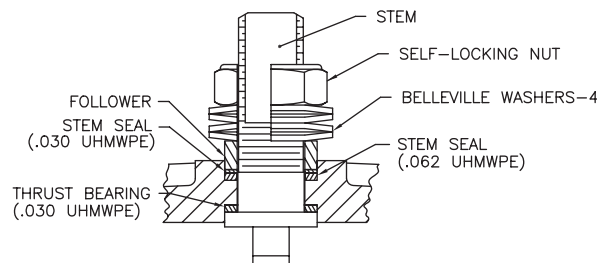

NOTE: For part colors, see color chart on back page.

1/4"-2" CPT Valve Stem Builds

Revision R0 Valve with P or T Seat

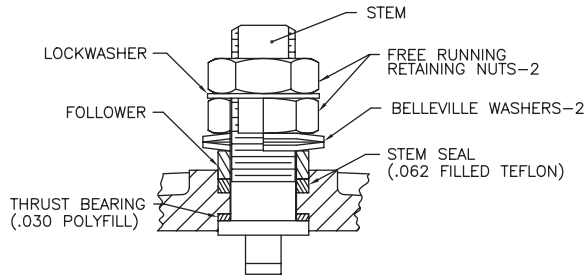

Revision R0 Valve with UHMWPE U Seat

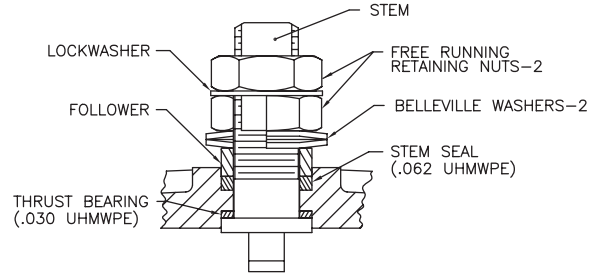

Revision R0 Valve with High-per Fill X Seat

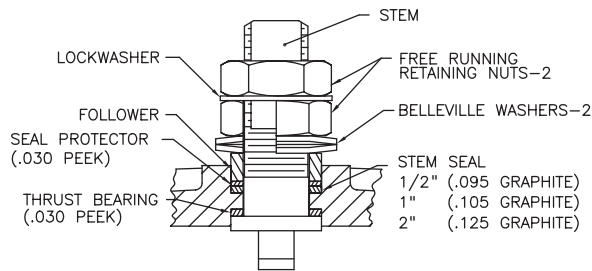

Revision R0 Valve with G Seat

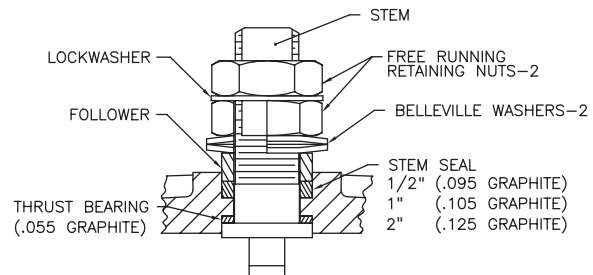

COLOR CHART FOR VARIOUS STEM COMPONENT MATERIALS

MATERIAL	COLOR
POLYFILL	BLACK
PEEK	TAN
GRAPHITE	SILVER GRAY
CARBON FILLED PTFE	BLACK
UHMWPE	OPAQUE WHITE
DELTRIN	BROWN
FILLED TFE	OFF WHITE

Flowserve Corporation has established industry leadership in the design and manufacture of its products. When properly selected, this Flowserve product is designed to perform its intended function safely during its useful life. However, the purchaser or user of Flowserve products should be aware that Flowserve products might be used in numerous applications under a wide variety of industrial service conditions. Although Flowserve can (and often does) provide general guidelines, it cannot provide specific data and warnings for all possible applications. The purchaser/user must therefore assume the ultimate responsibility for the proper sizing and selection, installation, operation, and maintenance of Flowserve products. The purchaser/user should read and understand the Installation Operation Maintenance (IOM) instructions included with the product, and train its employees and contractors in the safe use of Flowserve products in connection with the specific application.

While the information and specifications contained in this literature are believed to be accurate, they are supplied for informative purposes only and should not be considered certified or as a guarantee of satisfactory results by reliance thereon. Nothing contained herein is to be construed as a warranty or guarantee, express or implied, regarding any matter with respect to this product. Because Flowserve is continually improving and upgrading its product design, the specifications, dimensions and information contained herein are subject to change without notice. Should any question arise concerning these provisions, the purchaser/user should contact Flowserve Corporation at any one of its worldwide operations or offices.

For more information about Flowserve Corporation, contact www.flowserve.com or call USA 1-800-225-6989.

FLOWSERVE CORPORATION
FLOW CONTROL DIVISION
 1978 Foreman Drive
 Cookeville, Tennessee 38501 USA
 Phone: 931 432 4021
 Facsimile: 931 432 3105
www.flowserve.com